



# VLA-521T.NPT

3pc-Design Stainless Steel Ball Valve  
NPT - Thread



DN8 - DN100

- 3pc design
- For automation application
- Full bore
- Pressure range **PN 63**
- **NPT** - Threads acc to **ANSI B 1.20.1**
- ISO-Top mountig flange acc. to ISO5211
- Temperature range -10°C / +200°C

- Anti-Blow-Out stem
- VLA - suitable for **Ex** applications

On request:

- Different sealing materials
- For steam applications
- Locking device
- Manual operated
- Further options

Standard		
ISO9001	PED	TA Luft
Antistatic		
On request		
FDA	EC1935	

1/4"/DN8 - 2 1/2"/DN65

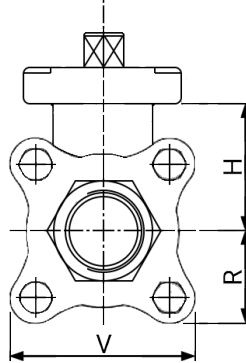
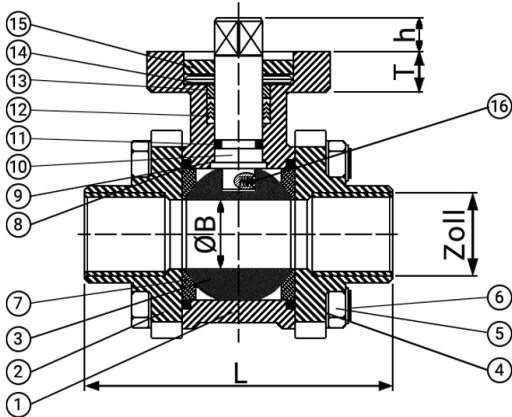

3"/DN80 - 4"/DN100

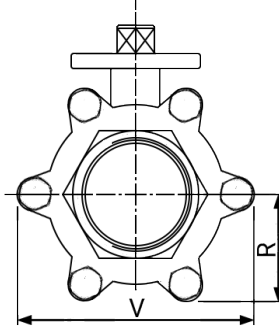

	Parts list	Qty.	Material
1	Body	1	1.4408
2	Cap	2	1.4408
3	Ball	1	1.4408
4	Washer	4-12	1.4301
5	Nut	4-12	A2-70
6	Screw / Bolt	4-6	A2-70
7	Ball seat	2	PTFE
8	Body seal	2	PTFE
9	Thrust washer	1	PTFE
10	Stem	1	1.4401
11	O-Ring	1	Viton
12	Stem packing	1 Set	PTFE
13	Gland ring	1	1.4301
14	Disc spring	2	1.4310
15	Gland nut	1	1.4301
16	Antistatic-device	1	1.4401

<sup>1</sup> PTFE/PTFE conductive

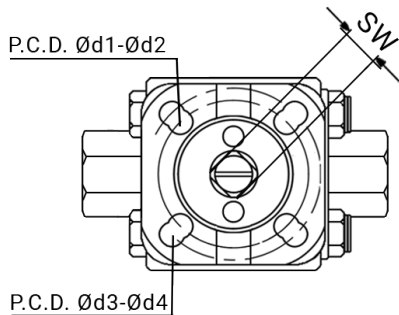

Inch	DN	L	ØB	H	T	R	V	h	SW	ØD1	ØD2	ØD3	ØD4	ISO 5211	Nm <sup>a</sup>	[kg]
1/4"	8	65	16	31	9	23,5	47	9	9	36	6	42	6	F03/F04	6	0,6
3/8"	10	65	16	31	9	23,5	47	9	9	36	6	42	6	F03/F04	6	0,6
1/2"	15	75	16	31	9	23,5	47	9	9	36	6	42	6	F03/F04	10	0,65
3/4"	20	80	20	35	9	27	53,5	9	9	36	6	42	6	F03/F04	14	0,85
1"	25	90	25	42	10	30	60,5	12	11	42	6	50	7	F04/F05	17	1,25
1-1/4"	32	110	32	48	10	35,5	71	12	11	42	6	50	7	F04/F05	24	1,9
1-1/2"	40	120	38	55	13	40,5	81,5	15,5	14	50	7	70	9	F05/F07	29	2,9
2"	50	140	50	64	13	50	100	15,5	14	50	7	70	9	F05/F07	44	4,5
2-1/2"	65	185	65	85	13	53,5	127	18,5	17	70	9	102	11	F07/F10	78	9,3
3"	80	205	80	97	13	83,5	188	18,5	17	70	9	102	11	F07/F10	112	14,4
4"	100	240	100	118	16	97,5	221	24	22	-	-	102	11	F10	140	22,2

Dimensions in mm

<sup>a</sup> incl. 30% safety factor  
→ für non-greased media x 1,3  
For more informations, please see the torque table