



VL-521P-ISO-AS-M

3pc-Design-Stainless Steel Ball Valve for Hygienic Applications
Orbital-Welding Ends - ISO



DN8 - DN100

- 3pc design
- for autom applic. / manual operated
- Pressure range **PN 63**
- **Orbital Welding ends**
- **Dimensions acc. ISO 1127 / DIN EN 10357 Serie C**
- Passage polished < 0,8 µm
- E-polished surface

- **Material 1.4435 delta Fe < 1%**
- Full bore
- Mounting top acc. ISO 5211
- Temperature range -10°C / +200°C
- Casting hand lever - e-polished
- Anti-Blow-Out Stem
- Locking device

On request:

- Different passage polishes (<0,5, etc)
- Different sealing materials
- with Cavity fillers
- Further options

Standard		
ISO9001	PED	TA Luft
FDA	EC1935	
On request		
ATEX		

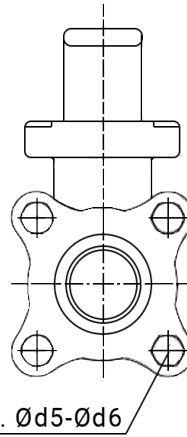
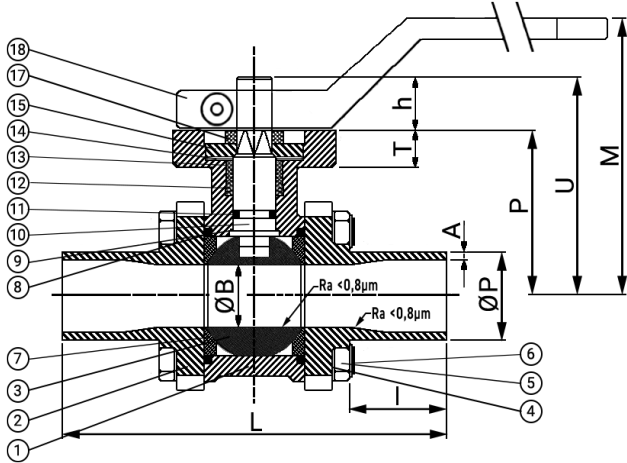

P.C.D. Ød5-Ød6

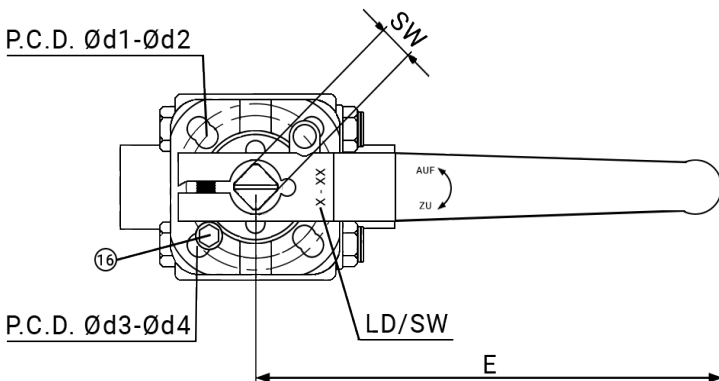

P.C.D. Ød1-Ød2

P.C.D. Ød3-Ød4

Parts list	Qty.	Material
1 Body	1	1.4435
2 Cap	2	1.4435
3 Ball	1	1.4435
4 Washer	4-12	1.4401
5 Nut	4-12	1.4401
6 Screw / Bolt	4-6	A4-70
7 Ball seat	2	RPTFE-FDA ¹
8 Body seal	2	PTFE-FDA
9 Thrust washer	1	PTFE-FDA
10 Stem	1	1.4404
11 O-Ring	1	Silicone
12 Stem packing	1 Set	PTFE-FDA
13 Gland ring	1	1.4401
14 Disc spring	1-2	1.4310
15 Gland nut	1	1.4401
16 Stopper	1	1.4401
17 Spacer ring	1	PTFE-FDA
18 Casting hand lever	1	1.4408

¹ PTFE/Stainless steel-FDA

DN	Inch	L	ØB	ØP	P	U	M	T	A	I	E	LD*	h	SW	Ød1	Ød2	Ød3	Ød4	Ød5	Ød6	ISO 5211	Nm ^a	[kg]
8	1/4"	100	10	13,5	40	49	64	9	1,6	23	125	F03	9	9	36	6	42	6	47	9	F03/F04	-	0,75
10	3/8"	100	14	17,2	40	49	64	9	1,6	23	125	F03	9	9	36	6	42	6	47	9	F03/F04	6	0,75
15	1/2"	100	16	21,3	40	49	64	9	1,6	25	125	F03	9	9	36	6	42	6	47	9	F03/F04	10	0,75
20	3/4"	105	20	26,9	44	53	68	9	1,6	25	125	F03	9	9	36	6	42	6	54	9	F03/F04	14	0,95
25	1"	115	25	33,7	52	64	91	10	2	25	189	F04	12	11	42	6	50	7	62	9	F04/F05	17	1,4
32	1-1/4"	140	32	42,4	58	70	97	10	2	33	189	F04	12	11	42	6	50	7	76,5	11	F04/F05	24	2,2
40	1-1/2"	150	38	48,3	68	80	107	13	2	33	221	F05	12	14	50	7	70	9	87	11	F05/F07	29	3,15
50	2"	170	50	60,3	77	93	116,5	13	2	33	221	F05	16	14	50	7	70	9	108	12	F05/F07	44	4,75
65	2-1/2"	220	65	76,1	98	117	154,5	13	2	40	302	F07	19	17	70	9	102	11	137	17	F07/F10	78	9,85
80	3"	300	80	88,9	110	129	166,5	13	2,3	65	302	F07	19	17	70	9	102	11	161	17	F07/F10	112	15,05
100	4"	325	100	114,3	138	162	219,5	16	2,3	65	350	F10	24	22	-	-	102	11	192,5	17	F10	140	23,4

Dimensions in mm

* LD= Locking device

^a incl. a safety factor of 30%

→ for further informations, please see the separate torque chart.