



# VL-501T-M

## 3pc-Design Stainless Steel Ball Valve Thread-Ends



**DN8 - DN100**

- 3pc design
- Manual operated
- Full bore
- Pressure range **PN 63**
- Length acc. DIN 3202 **M3** / DIN EN 16722
- Threads acc. DIN 2999 / DIN EN 10226-1
- Temperature range -10°C / +200°C

- Anti-blow-out stem

On request:

- Different sealing materials
- For steam application
- Locking device
- Further options

Standard	
ISO9001	PED

On request	
FDA	EC1935

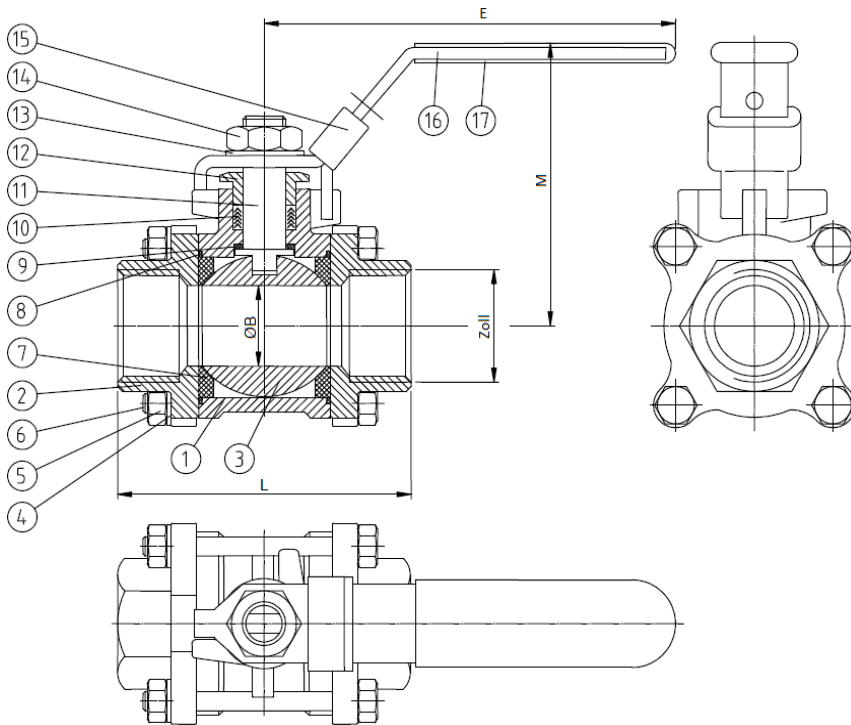

	Parts list	Qty.	Material
1	Body	1	1.4408
2	Cap	2	1.4408
3	Ball	1	1.4408
4	Washer	4-12	1.4301
5	Nut	4-12	A2-70
6	Screw / Bolt	4-6	A2-70
7	Ball seat	2	PTFE
8	Body seal	2	PTFE
9	Thrust washer	1	PTFE
10	Stem packing	1 Set	PTFE
11	Stem	1	1.4401
12	Gland nut	1	1.4301
13	Washer	1	1.4301
14	Nut	1	1.4301
15	Locking device	1	1.4301
16	Hand lever	1	1.4301
17	Sleeve	1	Plastic

<sup>1</sup> optional

Inch	DN	L	ØB	M	E	[kg]
1/4"	<b>8</b>	60	11,5	55	97,5	0,4
3/8"	<b>10</b>	60	13	55	97,5	0,4
1/2"	<b>15</b>	75	16	64	125,5	0,65
3/4"	<b>20</b>	80	20	67	125,5	0,85
1"	<b>25</b>	90	25	83	143,5	1,25
1-1/4"	<b>32</b>	110	32	89	143,5	2
1-1/2"	<b>40</b>	120	38	100	203,5	2,8
2"	<b>50</b>	140	51	108	203,5	4,5
2-1/2"	<b>65</b>	185	65	150	251,5	9,05
3"	<b>80</b>	205	80	161	251,5	14,15
4"	<b>100</b>	240	100	180	291,5	21,7

Dimensions in mm